

APPLICATION NOTE
AN022

6" Recessed Downlights

2011.07.12



1. Overview

Future Lighting Solutions has developed an LED-based recessed downlight system leveraging LUXEON® LEDs, providing a complete solution to enable applications in key market segments, such as indoor general lighting.

The design of the 6" downlight consists of a fixture that includes an integrated optical, thermal, and power solution, as well as a light engine that can be connected to different drivers demonstrating different power solutions.

All the solutions described in this application note are available at Future Lighting Solutions to enable the implementation of the system for prototyping or volume production.

Demo kits that include the lighting units have been assembled to showcase the functionality of the design and prove its ability to serve the market needs. Figure 1 shows the kit with the fixture, the light engine, and their power solutions assembled.

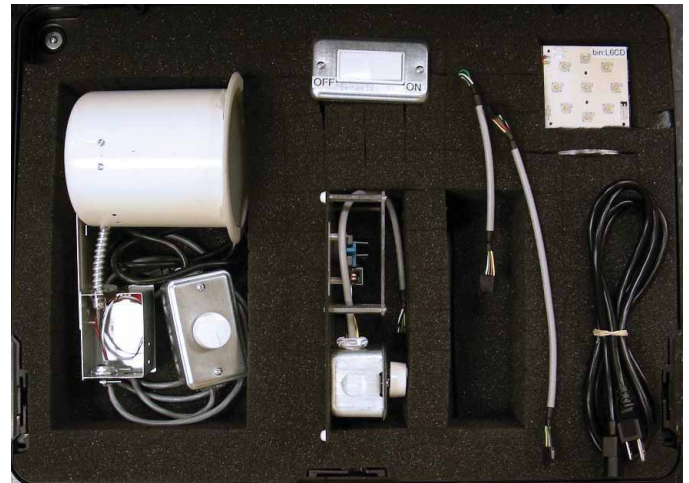

Figure 1. Demo kit for the 6" downlight

The target design specifications for the 6" downlight are shown in Table 1. These specifications also meet the ENERGY STAR® requirements for Solid State Lighting.

Target Luminaire Light Output	575lm
Target Area (from specified distance) that the Light Output is Attempting to Cover	Zonal lumen density = min. 75% @ 60°
Target Luminaire Efficacy	35lm/W
Target Luminaire Lifetime	3 years, 50k hours
Target Luminaire Color Temperature	Residential: 2700K, 3000K, 3500K Non-residential: 2700K - 5000K
Target Luminaire CRI	75
Input Voltage Range	Universal AC or dedicated AC (120V or 230V)
Power Factor Requirements	0.7 residential, 0.9 commercial
Dimming	Triac

Table 1. ENERGY STAR requirements for 6" downlight

2. Design Analysis

The SSL Designer online tool (www.futurelightingsolutions.com/ssldesigner) takes the target light specifications such as the efficacy, illuminance, system lifetime, along with the maximum LED drive current as input parameters. It then determines the required minimum number of LEDs to meet the provided specifications. Moreover, it calculates the usable light (lm), the usable efficacy (lm/W), and the total power consumed by the LED-based system (W), amongst other output parameters.

In order to meet the specifications for the 6" downlight application, the SSL designer analysis results are as follows:

• Input Parameters:

After selecting the target market and application, a lumen output of 625 lumens is set. Also, based on the requirements in Table 1, 75% of that lumen output is set to be from 0° – 60°. The fixture is assumed to be at a height of 2.5m. The input section with the set parameters is shown in Figure 2.

• LED System vs. Conventional Lamp System Performance Comparison:

After entering the application input parameters and entering basic information about the light source, SSL Designer calculates the required LED system performance, including the LED count and drive current. In addition, the tool calculates the performance of a conventional lamp system that meets the same specifications. Figures 3 and 4 below show the performance calculations of both cases respectively. The results state that 9 LEDs driven at 500mA current are required to meet and exceed the specifications of light output, efficacy, and lifetime, while maintaining the junction temperature at an acceptable value for suitable LED operation. The total power consumption of the LED system was 15.99W, after losses, while that of the conventional lamp system was 28.24W. This shows the significant improvement achieved, in terms of power consumption, when using LEDs in downlight applications.

Figure 2. SSL Designer Input

LED System Performance:		Collapse
LED System Performance Characteristic	Value	
System LED Count	9 LEDs	
Average LED Drive Current	500 mA	
Average LED Forward Voltage	3.02 V	
Average LED Power Consumption	1.51 W	
Total LED Power Consumption	13.59 W	
Total LED System Power Cons. (w/ losses)	15.99 W	
Average LED Junction Temperature	61 °C	
Average LED Flux	104 lm	
Total LED Flux	938 lm	
Total LED System Flux (w/ losses)	751 lm	
Average LED Efficacy	69.03 lm/W	
Average LED System Efficacy (w/ losses)	46.94 lm/W	
LED System Operating Lifetime (B50, L70)	60,000 hrs	

Figure 3. LED System Performance

Conventional Lamp System Performance:		Collapse
Lamp System Performance Characteristic	Value	
System Lamp Count	1 lamp	
Average Lamp Power Consumption	24.00 W	
Total Lamp Power Consumption	24.00 W	
Total Lamp System Power Cons. (w/ losses)	28.24 W	
Average Lamp Flux	1,800 lm	
Total Lamp Flux	1,800 lm	
Total Lamp System Flux (w/ losses)	900 lm	
Average Lamp Efficacy	75 lm/W	
Average Lamp System Efficacy (w/ losses)	31.88 lm/W *	
Average Lamp Lifetime	20,000 hours	
System Lamp Failures (9 yrs)	2 failures	
Program Lamp Failures (9 yrs)	2,000 failures	

* Target system efficacy (45 lm/W) can't be reached. It is recommended to select a lamp with a higher efficacy.

Figure 4. Conventional Lamp System Performance



• **LED Payback:**

One more option in the tool is to calculate the payback of using an LED system as compared to using a conventional lamp system. After defining cost information for both systems, the tool produces payback information such as power savings, cost savings, and payback period. Figure 5 shows that the payback period for using an LED-based system for recessed downlights is 2.5 years.

Note: The above SSL Designer case is available as a default scenario that can be loaded in the tool and used as reference. Under "Target Application" select "Recessed Downlight – 6 Inch (FLS AN022)" to load all the case parameters.

LED Payback Summary:		Collapse ▾
LED Program Payback Summary Item	Value	
Program Annual Power Savings in kWh	80,430 kWh	
Program Annual Savings in CO ₂ (US)	58 tonnes*	
Program Annual Savings in CO ₂ (Eur)	38 tonnes**	
Program Lifetime Power Savings in kWh	723,872 kWh	
Program Lifetime Power Cost Savings	\$86,865	
Failure Bulb Replacement Cost Savings	\$26,000	
Failure Labor Cost Savings	\$17,500	
Failure Other Cost Savings	\$4,000	
Failure Total Cost Savings	\$47,500	
Product Variable & Fixed Total Cost Savings	(\$23,390)	
LED Program Total Cost Savings	\$110,975	
LED Program Payback in Years	2.5 years	

Calculated LED Program Payback: [?]

* Source: US Environmental Protection Agency (EPA) eGRIDweb Year 2005
** Source: UK's department for the environment, food and rural affairs (DEFRA) as of Feb 2009 averaged

Figure 5. LED Payback

3. LEDs and Board Design

The LUXEON LEDs form the basis of the LED-based recessed downlight reference design. Nine of these LEDs are used in each unit. While these LEDs are offered in different portfolios, the following options are the ones best suited to meet the requirements for this application:

- LUXEON Rebel Illumination Portfolio tested at 350mA
 - LXM8-PW30 :: 75lm min. flux / rated at 3000K and min. CRI of 80
 - LXM8-PW27 :: 70lm min. flux / rated at 2700K and min. CRI of 80

- LUXEON Rebel ES tested at 700mA
 - LXW9-PW27 :: 135lm typ. flux / 64lm/W efficacy and min. CRI of 90
 - LXW9-PW30 :: 145lm typ. flux / 69lm/W efficacy and min. CRI of 90
 - LXW8-PW35 :: 185lm typ. flux / 88lm/W efficacy and min. CRI of 80
 - LXW8-PW40 :: 200lm typ. flux / 95lm/W efficacy and min. CRI of 80
 - LXW8-PW50 :: 200lm typ. flux / 95lm/W efficacy and min. CRI of 80

- LUXEON A tested at 700mA and 85°C
 - LXH8-PW30 :: 165lm typ. flux / 82lm/W efficacy and min. CRI of 80
 - LXH8-PW27 :: 160lm typ. flux / 79lm/W efficacy and min. CRI of 80

The LUXEON LEDs above have an industry leading hot/cold factor, which generates increased light output at higher junction temperatures. Moreover, the LUXEON A is "hot" tested and binned at 85°C. This binning at operating temperature guarantees the performance specifications promised in the datasheet and delivers dependable output. LUXEON A offers "Freedom from Binning" which eliminates the need for color bin selection, delivering better color consistency and uniformity.

Note that the LEDs selected for the SSL Designer scenario above were LUXEON Rebel LXM3-PW61 LEDs from the Illumination Portfolio. For the Demo kit, the LXML-PWN1-0100 LEDs from the General Purpose White Portfolio were used.



3.1. Board Design and LED Connections

The 9 LEDs are connected in series on an FR4 board with thermal vias, as shown in Figure 6. The board dimensions are 85mm x 85mm, with 31mils of FR4 and 2oz Copper.

Moreover, the simpleLED® program from Future Lighting Solutions can be leveraged for this downlight reference design. This program provides a broad portfolio of light engines which consist of LUXEON LEDs on an FR4 board, with the option of secondary optics and onboard connectors.

This accelerates time to market and adds convenience to building the application.

While the simpleLED boards are offered in three form factors, namely linear, circular, and square, with different number of LEDs on the board, the board most suited for this downlight application is shown in Figure 7:

- Series :: 05713R
- Form Factor :: Circular
- Number of LEDs :: 9 LEDs
- Optics :: 10mm medium beam optic

Some features of these LED boards include:

- 3 year warranty
- UL recognized and CE approved
- Option for having on-board connector solder pads
- Broad offering of optics and color temperatures



Figure 6. LED board with optics

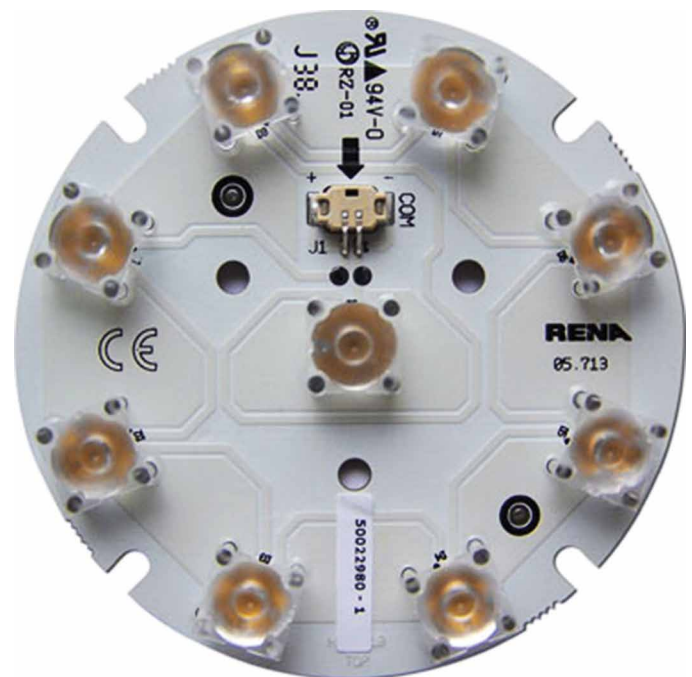

Figure 7. 9-LED circular simpleLED board

3.2. LED Module Solution

Future Lighting Solutions can also offer an alternative approach that will bring an LED-based downlight to market quickly and reliably. This approach is based on the Philips Fortimo Down Light Module (DLM) and Twistable DLM (TDLM). Leveraging remote phosphor technology, these modules provide consistent color temperature over different production runs. The Fortimo DLM is available in two versions, 1100 and 2000-lumen packages and the Fortimo TDLM is available in a 1100-lumen package. Thermal foldback and NTC control are built in the modules and driver, and both are supported by a 5-year warranty. The Philips Fortimo DLM and TDLM are shown in Figure 8.



Figure 8. Philips Fortimo DLM and TDLM

4. Optical Solutions

Two optical solution options are provided for the 6" downlight unit. The first is a Carclo 10mm frosted medium beam optic (p/n. 10413) placed over each LED, shown in Figure 9, providing an overall uniform illumination on the target surface. The optic has a viewing angle of 21°.



Figure 9. Carclo 10mm optic

The second option is a 90mm diameter Khatod 9-LED optic (p/n. PL1172). The optic allows for different focus levels (beam angles) which can be controlled by how far the optic is placed from the LEDs. The different beam angles can be Narrow (10°), Medium (30°) and Wide (60°). Figure 10 below shows the 9-LED optic and the different focus levels possible.

The fixture also has a diffuser that ensures uniform light output and eliminates hot spots. An operational fixture with a diffuser is shown in Figure 11. If the visual effect of a diffuser is not wanted, other viewing angle optics are available to be used for this application to generate an appropriate radiation pattern.

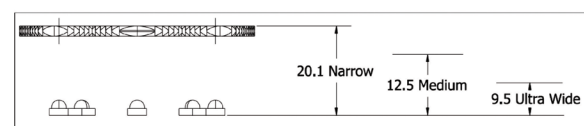
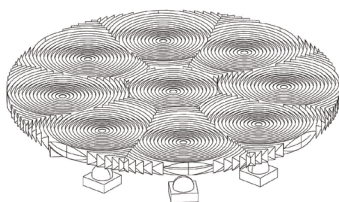

Figure 10. Khatod 9-LED optic and different focus levels



Figure 11. Operational 6" fixture

Reflectors from Alux Luxar have been designed and optimized for the Philips Fortimo DLM and TDLM to provide a comprehensive off-the-shelf portfolio that meets the downlights market requirements. A reflector from Alux Luxar is shown in Figure 12.



Figure 12. Reflector for Fortimo DLM from Alux Luxar

4.1. Optical Measurements

Optical measurements were made on the downlight fixture to measure the illuminance levels at different incident angles. At a reference height of 3m (10 feet) from the downlight diffuser to the floor, Table 2 shows the illuminance results measured with a Konica-Minolta CL-200 lux meter.

Incident Angle	Lux Level
0° (straight down)	146.0
15°	56.3
30°	12.5
40°	3.2
45°	2.0
50°	1.2
55°	0.8
60°	0.5
65°	0.2

Table 2. Optical measurement results for 6" downlight fixture

5. Thermal Solutions

5.1. Passive Cooling Solution

A 3.5" long black anodized finished extrusion heat sink, with 1.46°C/W thermal resistance, by Aavid Thermalloy was used to mount the LED board (p/n. 675903B03500G). The heat sink and its dimensions are shown in Figure 13.

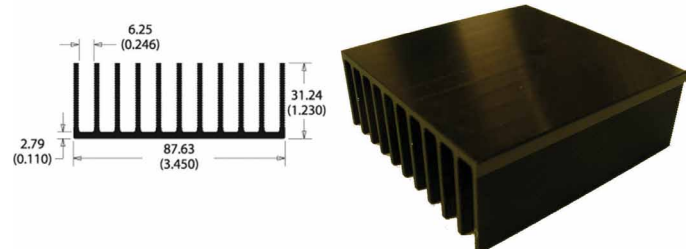

Figure 13. Aavid Thermalloy heat sink used for the 6" downlight

5.2. Active Cooling Solution

Another possible thermal solution is to use active cooling. Nuventix has developed a series of heat sinks that incorporate a SynJet® module which utilizes a patented actuator technology. This creates a turbulent flow as pulsated air-jets are directed at locations that need thermal management.

Nuventix has developed heat sink solutions specifically for the Philips Fortimo modules, namely DLM and TDLM. The SynJet® Downlight Cooler 120, shown in Figure 14, can be used for the Fortimo DLM, whereas the SynJet® CoolTwist Cooler can be used for the Fortimo TDLM.



Figure 14. Nuventix SynJet Downlight Cooler for the Fortimo DLM module

5.3. Thermal Simulations and Measurements

A thermal simulation was performed to evaluate the overall thermal performance of the fixture. QLED thermal simulation software (www.futurelightingsolutions.com/qled) was used to model the fixture and perform the simulation, as shown in Figure 15.

The QLED model was run with a forward current of 350mA, and ambient temperature of 20°C. The resulting junction temperature of the simulation was 71°C.

In addition to the thermal simulation, measurements using a thermocouple were taken on a fully operational assembly to monitor its thermal behavior. The thermocouple was placed at the solderability measurement point (T_s) as per the LUXEON Rebel Thermal Measurement Guidelines (AB33), shown in Figure 16.

The calculations below demonstrate how to obtain the junction temperature of the LED, taking into account the drive current, the LED forward voltage, and the thermal resistance from junction to the solderability measurement point:

$$T_s = 53.4^\circ\text{C} \text{ (thermocouple measurement)}$$

$$T_j = T_s + P \cdot R_{\theta(j-s)}$$

$$T_j = 53.4 + (0.35 \cdot 3) \cdot 16 = 70.2^\circ\text{C}$$

The calculation results from the thermocouple measurements closely match the QLED simulation results.

The thermal performance of the fixture was also analyzed at different drive currents using QLED thermal simulation software. The following table summarizes the results of these simulations:

Note: for these simulations $T_{AMB} = 25^\circ\text{C}$

Current (I_F)	Junction Temperature (T_j)
350mA	77.1°C
500mA	99.6°C
700mA	125°C

Table 3. Results summary of QLED simulations

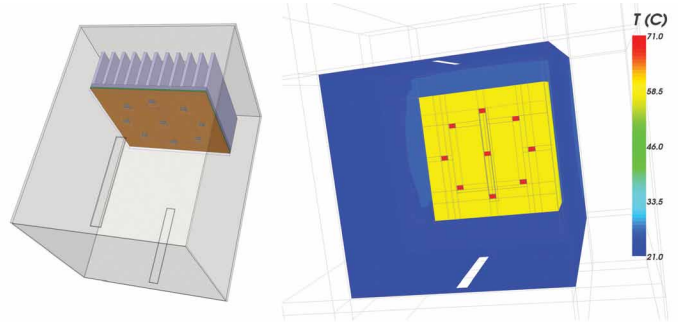

Figure 15. QLED thermal simulation of the 6" downlight fixture

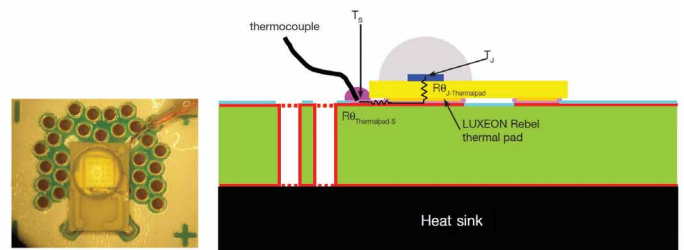

Figure 16. Thermocouple placement on solderability point of LUXEON Rebel

The results in Table 3 show that increasing the drive current from 350mA to 500mA and 700mA still maintains the junction temperature within an acceptable value for suitable LED operation. However, tolerances need to be considered such as ambient temperature, forward voltage and current tolerances, so as not to affect the performance and lifetime of the luminaire in prolonged operation periods.

6. Power Solutions

Various power solutions were evaluated and leveraged to enable the 6" downlight application.

6.1. Modular Driver Solutions

The nine LEDs of the 6" downlight reference design can be powered by a constant current driver. The following driver modules can be used to drive the LED board.

PHILIPS LIGHTING

The 9-LED board can be powered by the 12W driver from Philips Lighting, shown in Figure 17.

Two versions of the driver are available to accommodate regional input voltage differences. The part numbers of the drivers are:

- 120V :: LED120A0350C33F
- 207V - 264V :: 9137 006 15882

The following is a summary of the driver specifications:

- Output voltage range :: 2.4V – 33V
- Drive current :: 350mA
- Power factor :: >0.9
- Warranty :: 5 years

To power the Philips Fortimo DLM, a dedicated Fortimo driver is used. There are two versions, North American and European. The drivers have an output current range from 200mA to 700mA which is set using a resistor in the Fortimo DLM. This technique guarantees that all modules will provide a consistent level of light output.

For the Philips Fortimo TDLM, no external driver is needed.

MEAN WELL

Another option is the 17W Mean Well driver, shown in Figure 18.

The driver part number is:

- LPC-20-350

The following is a summary of the driver specifications:

- Input voltage range :: 90V – 264V
- Output voltage range :: 9V – 48V
- Drive current :: 350mA
- Efficiency :: 83%
- Warranty :: 2 years



Figure 17. Philips Lighting LED driver



Figure 18. Mean Well LED driver

ROAL

The 15W AC-DC ROAL TROPO driver, shown in Figure 19, can also drive the 9-LED board. Two versions of the driver are available to accommodate regional input voltage differences, i.e. 120V and 230V versions. The part numbers of the drivers are:

- 120V :: RLDD015L-350J
- 230V :: RLDD015H-350J



Figure 19. ROAL TROPO LED driver

The following is a summary of the driver specifications:

- Input voltage :: 120V / 230V
- Output voltage range :: 24V – 48V
- Drive current :: 350mA
- Dimming :: Triac
- Efficiency :: 80%
- Power Factor :: >0.9
- Warranty :: 5 years

Figure 20 shows the downlight fixture with the driver integrated and connected to the Triac dimmer.



Figure 20. Fixture of 6" downlight with integrated driver and Triac dimmer

6.2. IC-based Driver Solutions

The 9-LED board can also be powered using an IC-based driver with or without dimming options.

MARVELL

A non-dimmable solution leverages Marvell 88EM8081 IC which is a high performance and low cost controller with single stage flyback topology. This IC includes an adaptive control-loop design to achieve a PFC of 0.99 and a very low Total Harmonic Distortion level (THD). Figure 21 shows the schematic of a universal isolated LED driver with PFC. Due to its digital signal processing capabilities, this IC offers a small package and low system bill of material (BoM).

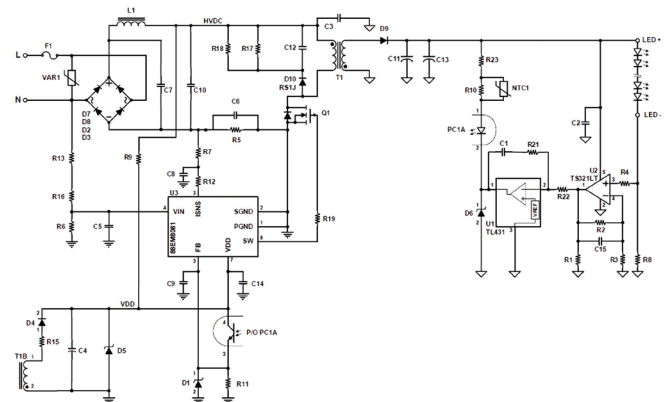

Figure 21. Universal Isolated LED Driver with PFC



CYPRESS SEMICONDUCTOR

Another driver IC solution can be CY8CLEDAC02 by Cypress which supports an isolated topology. This IC driver has an intelligent wall dimmer detection capability for leading edge and trailing edge dimmers and can go down to 2% of full light intensity. This enables easy integration with existing lighting control infrastructure. It's rated up to 25W output power and has a typical PFC > 0.7. The device's proprietary primary side sensing enables tight LED current regulation and eliminates the need for secondary feedback circuitry. No opto-couplers are necessary to meet UL isolation requirements, enabling flyback conversion with automatic isolation.

NXP

A 15W IC driver by NXP that supports isolated and non-isolated topologies is shown in Figure 22 (p/n. SSL2101). It can also be leveraged to power the 9-LED board. The board in the demo kit is implemented with an isolated topology. The driver can be easily integrated with existing lighting control infrastructure, such as Triac dimmers. It has a built-in over-temperature protection and an internal high-voltage power-switch and circuit that allow for instant start-up directly from the rectified mains voltage.

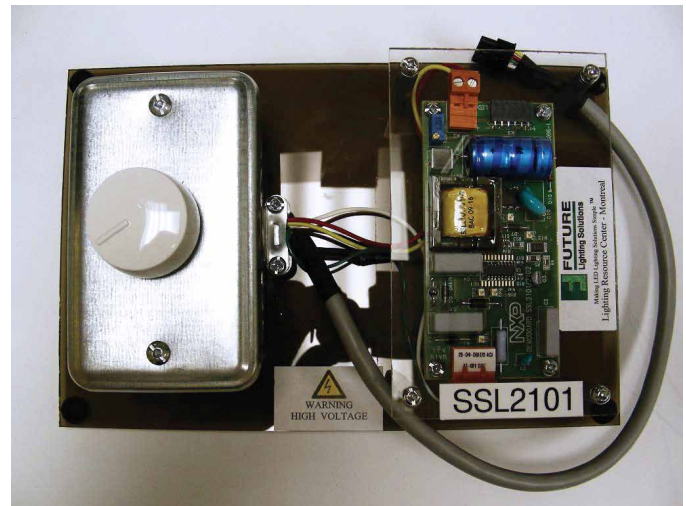

Figure 22. NXP SSL2101 AC-DC driver with Triac dimmer

NATIONAL SEMICONDUCTOR

Another solution, shown in Figure 23, is a non-isolated IC driver by National with an external FET (p/n. LM3445). This driver is an AC-DC buck (step-down) constant current controller designed to be compatible with Triac dimmers. It is capable of driving LEDs at up to and greater than 1000mA current and provides thermal shutdown and under-voltage lockout features.

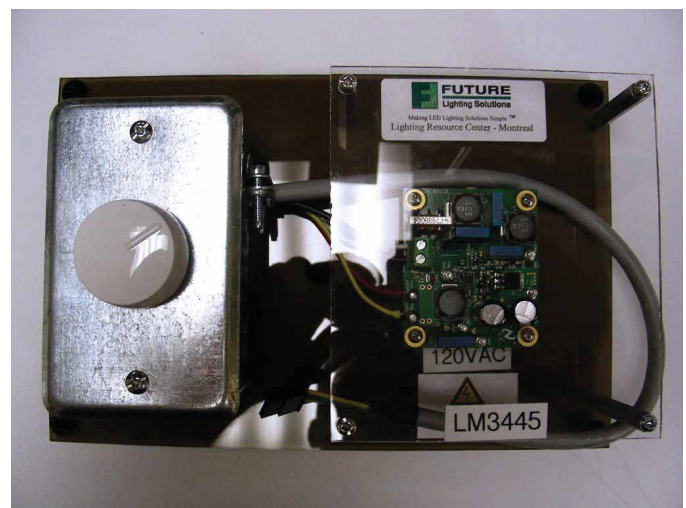

Figure 23. National LM3445 AC-DC driver with Triac dimmer



7. Connectors

A connector system can be used with the recessed downlight application to adapt to different design setups. The following are possible connector systems:

- **Tyco inverted thru board connector system**

The inverted thru board connector system allows for conveniently placing all the connections from the underside of the board, as shown in Figure 24. This eliminates wire dress management issues and enables a low profile design. The part numbers for this connector system are:

- i. Inverted thru board connectors: 2106091-1
- ii. Inverted thru board mini CT plug assy.: 2058943-1

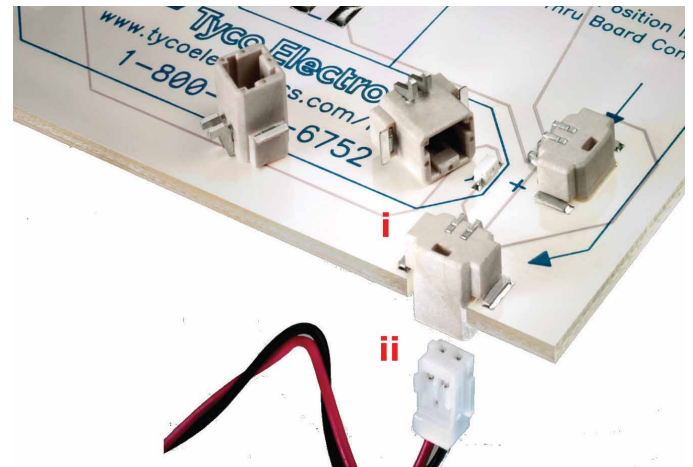

Figure 24. Tyco inverted thru board connector system

- **Tyco sealed connector system**

The sealed connector system, shown in Figure 25, is a low profile, single row LED connector system that offers protection to the connectors in the system. The part numbers for this connector system are:

- i. Wire-to-board right angle header: 2106056
- ii. Wire-to-board vertical header: 2106053
- iii. Wire-to-wire receptacle contact: 2106123
- iv. Wire-to-wire tab contact: 2106124
- v. Plug assembly (for header, recept., tab): 2106135

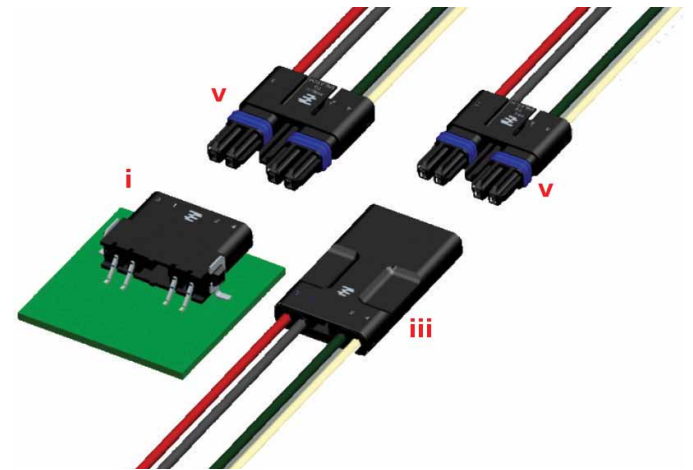

Figure 25. Tyco sealed connector system

- **AVX 9159 connector system**

The AVX connector system, shown in Figure 26, offers board-to-board connectors for daisy chaining multiple LED boards together in series. The part numbers for this connector system are

- i. Wired plug with latch: 11-9159-002-101-116
- ii. Standard socket: 20-9159-002-101-116
- iii. Standard plug: 10-9159-002-101-116
- iv. Top loading socket: 22-9159-002-101-116
- v. Shorting socket: 58-9159-002-000-006

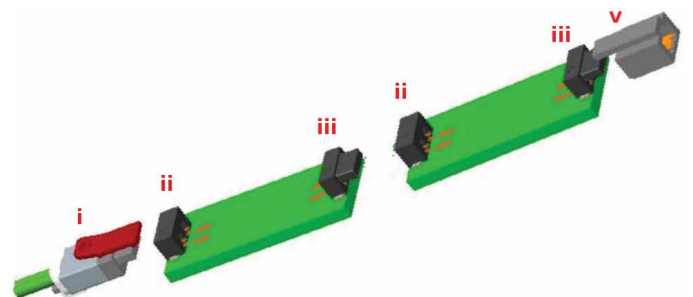

Figure 26. AVX 9159 connector system

8. Conclusion

The 6" recessed downlights leveraging LUXEON® LEDs developed by Future Lighting Solutions have proven to satisfy the requirements of light output, efficacy, and lifetime to enable lighting applications in the general lighting market.

The optical, thermal, and power solutions offered are geared towards optimal performance and longevity of the LED-based system. This application note has illustrated the flexibility of this design in accommodating different optical and power solutions.

CONTACT INFORMATION

www.FutureLightingSolutions.com

In North America:

1-888-LUXEON2

Americas@futurelightingsolutions.com

In Europe:

00-800-44FUTURE

Europe@futurelightingsolutions.com

In Asia:

+800-LUMILEDS

Asia@futurelightingsolutions.com

In Japan:

+81-0120-667-013

Japan@futurelightingsolutions.com

Future Electronics and Future Lighting Solutions make no representation or warranty, express or implied, as to the accuracy, completeness, reliability or timeliness of the information provided herein. Any and all information is furnished on an "as is" basis and only as an accommodation to customers and not based upon any legal or contractual obligation to do so. Conclusions drawn from or actions undertaken on the basis of such information are the sole responsibility of the user. Future Electronics and Future Lighting Solutions specifically disclaim any liability or responsibility for any information provided herein or for any loss or damage resulting from the use of or reliance upon any such information.

